



**Edwardsburg Public Schools
Intermediate and Primary School
Renovation
PRE-BID MEETING**

March 4, 2025

PRE-BID MEETING



Edwardsburg
INTERMEDIATE SCHOOL



Edwardsburg
PRIMARY SCHOOL

Intermediate School
27157 US 12
Edwardsburg, MI 49112

Primary School
69100 Section Street
Edwardsburg, MI 49112

OWNER



Edwardsburg Public Schools

- **Dr. Courtney Szucs, Superintendent**
- **Gail Enders, Director of Finance & Operations**
- **Christine Neff, Maintenance & Transportation Director**



ARCHITECT



TowerPinkster

- Sue Potter

sue.potter@towerpinkster.com

616-403-8938

TowerPinkster
Architecture · Engineering · Interiors

THE SKILLMAN TEAM



ACCOUNT EXECUTIVE

- Michael Kounelis
- 269-207-3049
- mkounelis@skillman.com

PROJECT MANAGER

- Max Tackett
- 269-568-2433
- mtackett@skillman.com

PROJECT ENGINEER

- Will Karnes
- 269-908-9684
- wkarnes@skillman.com

SITE MANAGER

- Jay Bachtel
- 269-830-8685
- jmbachtel@skillman.com

ADMIN. ASSISTANT

- Caralee Sokolowski
- 269-350-5757
- csokolowski@skillman.com

CONSTRUCTION DOCUMENTS



Construction Documents are available at:
www.skillmanplanroom.com

Bidding Contractors are required to pay for printed Documents. The electronic files are available at no cost.

SCOPE OF WORK



- **Complete renovation of the Intermediate and Primary Offices. Including wall, ceiling, and storefront demolition. New metal stud walls and drywall, acoustical ceilings, interior and exterior doors, casework, flooring, painting, tiled Health Room, aluminum storefront, new Primary VUV, lighting, card access/lock-down buttons, canopy roofing, and underground drainage/sidewalk replacement.**
- **Intermediate Area of Renovation = 1,977 s.f.**
- **Primary Area of Renovation = 880 s.f.**

CONSTRUCTION TIMELINE



Review Section 01 32 00 – Schedules & Reports.

Anticipated Construction Start Date: June 12, 2025

Anticipated Construction

Completion Date: August 25, 2025

ANTICIPATED CHALLENGES



- **Expediting Submittals and Material Procurement**
- **State Review Time and Permitting**
- **Isolating Areas of Disturbance**
- **Expediting Partial and Full State Inspections**
- **Coordinating Asbestos Floor Tile removal in the Office and Reception Rooms**
- **Shoring and Structural Steel Installation at the Primary Office**

FLOOR PLANS / SITE PLANS

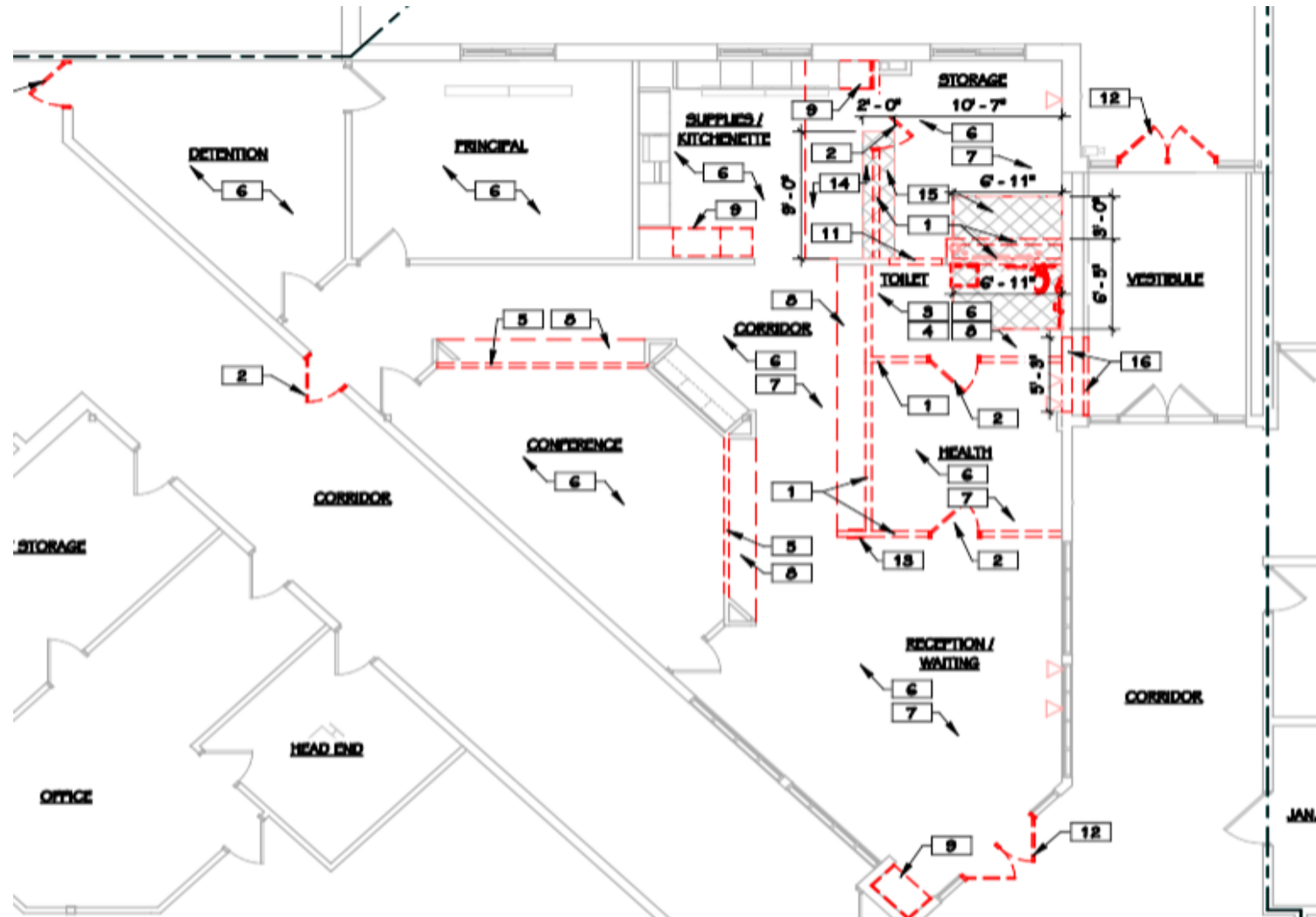

Intermediate Demo Plan

FLOOR PLANS / SITE PLANS

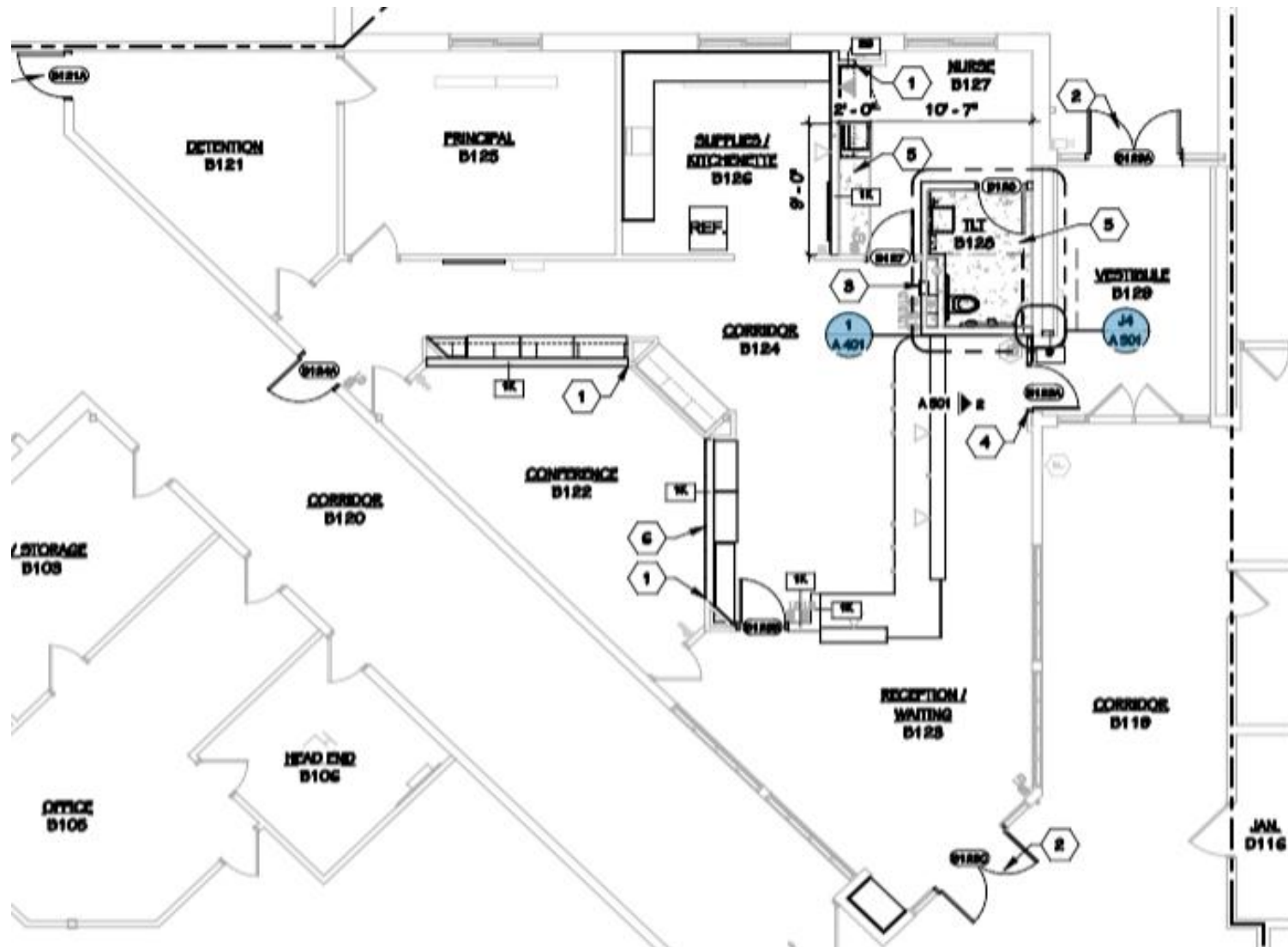

Intermediate Floor Plan

FLOOR PLANS / SITE PLANS

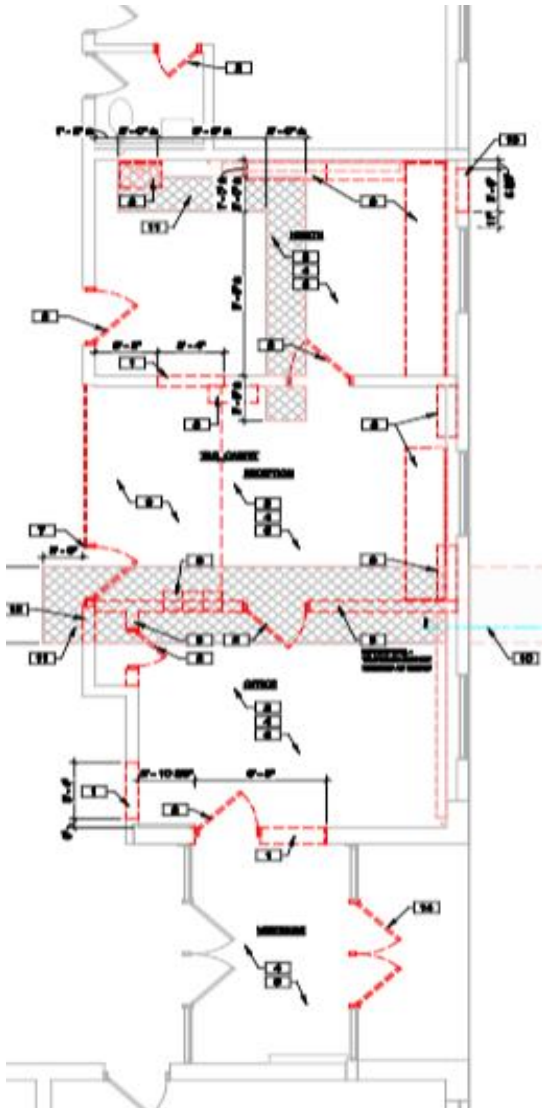

Primary Demo Plan

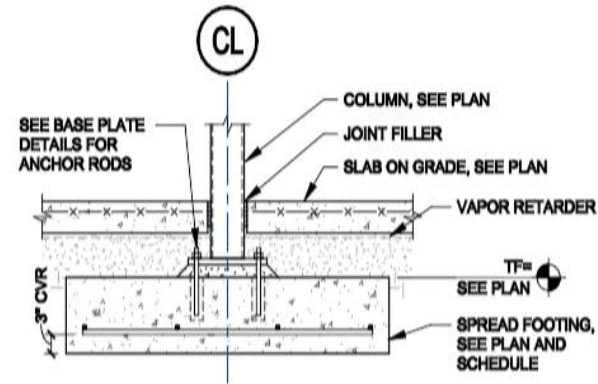

1 TYP SPREAD FOOTING
S 101B 1/2" = 1'-0"

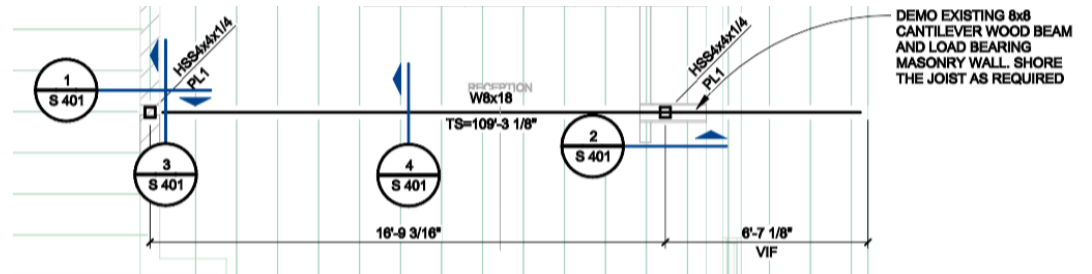

Primary Roof Framing Plan

FLOOR PLANS / SITE PLANS

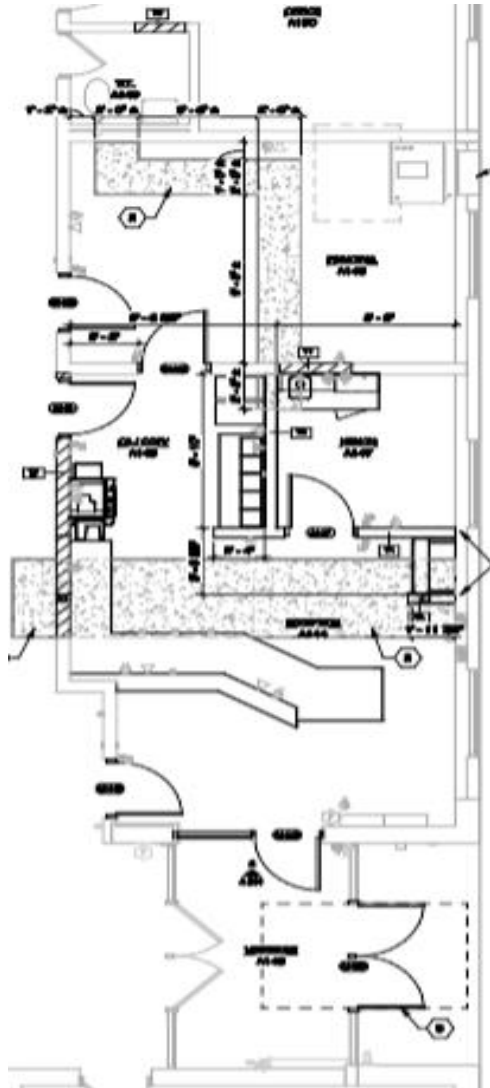

Primary Floor Plan

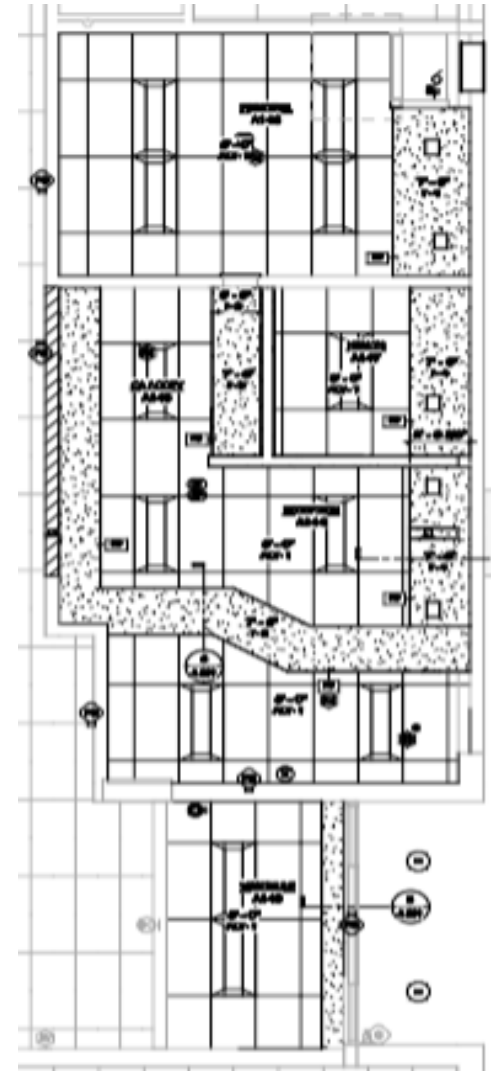

Primary Ceiling Plan

BID CATEGORIES



BID CATEGORY NO. 1	General Trades
BID CATEGORY NO. 2	Mechanical
BID CATEGORY NO. 3	Electrical

MULTIPLE CONTRACT SUMMARY



**Review Section 01 12 00 – Multiple Contract Summary.
Review all Specification Sections that are in your Scope
of Work.**

- **1.05 Prime Contractors Use of Premises**
- **1.07 Occupancy Requirements**
- **1.09 Permits, Fees and Notices**
- **1.10 Labor and Materials. A, B, & C**
- **1.14 Schedules of Contract Responsibilities-Scope**
- **1.16 Time of Commencement and Completion**

SITE LOGISTICS PLAN

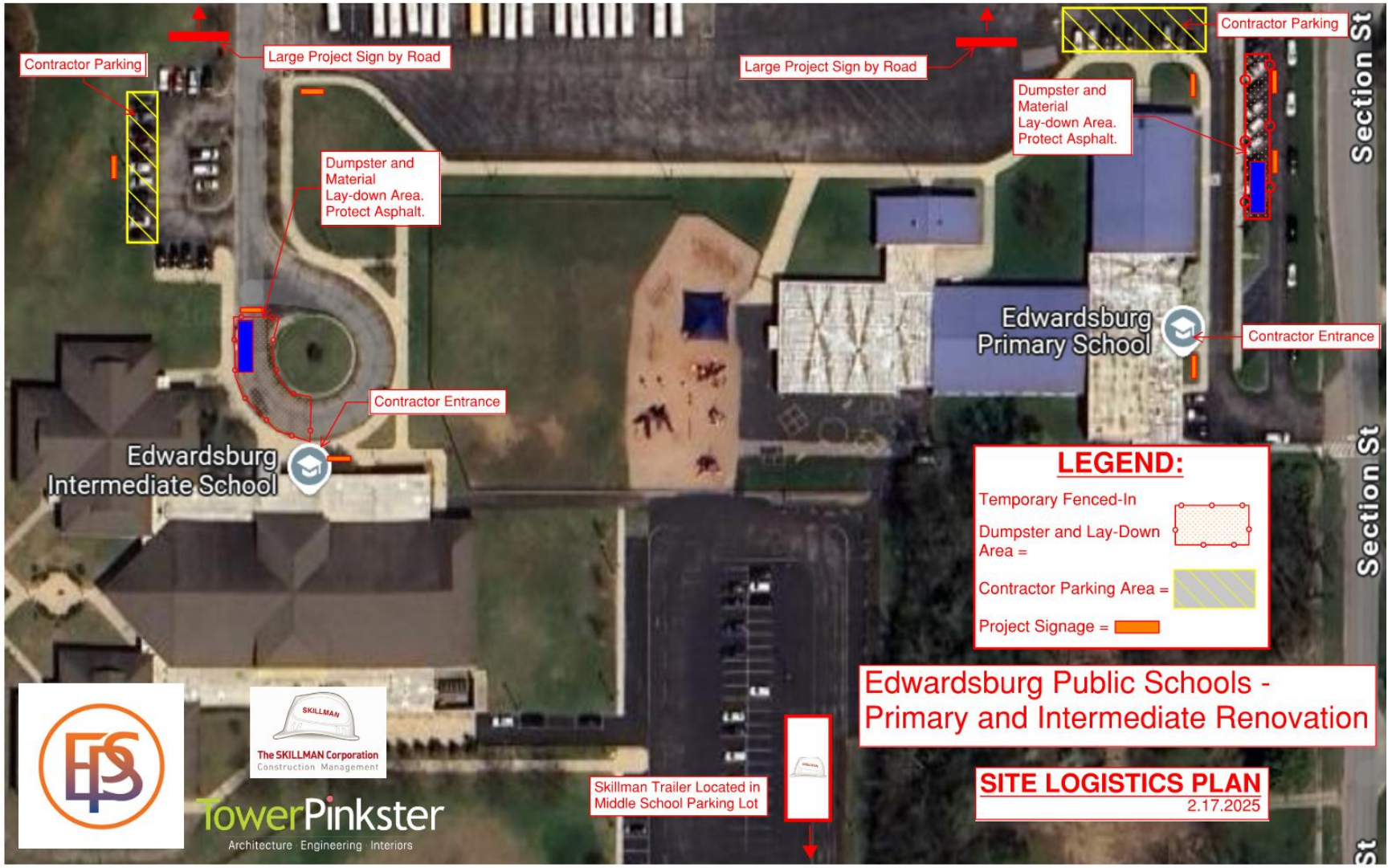

Skillman Trailer Located in Middle School Parking Lot





REQUIRED FOR EVERY CONTRACTOR

- **No subscription is required**
- **Current set of documents**
- **Issues tracking**
 - Safety
 - QA/QC
 - Noncompliance
 - Work Completion List
 - Punch List
- **As-built record drawings**

ALTERNATES



Review Section 01 23 00 for Alternates that may alter your Scope of Work.

- **ALTERNATE NO. 01**: State the cost to provide all work associated with the South Canopy shown on the Roof Plans on the **Intermediate School Plans**.

ALLOWANCES



Review Section 01 21 00 for Allowances that apply to your Scope of Work.

Bid Category No. 01	General Trades	\$10,000
Bid Category No. 02	Mechanical	\$10,000
Bid Category No. 03	Electrical	\$10,000

INCLUDE THIS AMOUNT IN YOUR BASE BID.

RFI PROCESS



Each Bidder is encouraged to contact the Architect and Construction Manager if problems occur or questions arise in analyzing the Drawings and Specifications, where additional clarification or information would be helpful in the preparation of a proper bid.

Submit all questions in writing to: Max Tackett: mtackett@skillman.com

All RFIs must be received before: **March 11, 2025, by Noon**

SUBSTITUTION REQUESTS



Prior to receipt of bids, the Architect will consider proposals for substitution of materials, equipment, and methods only when such proposals are submitted in writing within the time period stated before the date and time set for receipt bids, and are accompanied by full and complete technical data and other information required by the Architect to evaluate the proposed substitution.

Request for product approval shall be submitted on the Substitution Request Form and sent to: Max Tackett & Sue Potter:

mtackett@skillman.com

sue.potter@towerpinkster.com

INSTRUCTIONS TO BIDDERS



Review Section 00 10 00 for Instructions to Bidders.

- **1.02 Bidders Examination & Representation**
- **1.10 Bidding Procedures, (R.) Sales Tax (include in bid)**
- **1.15 Determination of Lowest Responsible & Responsive Bid**
- **1.17 Execution of The Contract**
- **1.19 Wage Rates-NOT APPLICABLE.**

BID FORM



Review and fully complete the Bid Form 00 31 00

Complete all alternates on the Bid Form that may affect your Scope of Work.

BIDDERS' REMINDER LIST



	YES	NO
Have you properly and completely executed the Bid Form (Section 00 31 00)?		
Is the Bid Total written in both words and figures?		
Are the Alternate quantities in both words and figures and noted as Add or Deduct ?		
Is the Non-Collusion Affidavit , part of the Bid Form, signed, & notarized?		
Is the Familial Disclosure Affidavit , part of the Bid Form, signed and notarized?		
Is the Iran Sanctions Act Certificate of Compliance , part of the Bid Form, signed and notarized?		
Have you enclosed a certified check or Bid Bond ? (Note: bond must be signed by Surety and Principal)		
Have you included your company's Financial Statement ?		
<p>On the outside of the envelope containing your Bid have you indicated:</p> <ul style="list-style-type: none"> The Project Name Bidder's Name Bid Category No. Date and Time of Bid Opening Owner's Address Address to Where Bid is to be Delivered if different from Owner's Address 		

IF ANY OF THE REQUIRED BIDDING DOCUMENTS ARE NOT INCLUDED, DATED, OR PROPERLY EXECUTED, THE CONTRACTOR'S BID MAY NOT BE ACCEPTED.

BID TO AWARD TIMELINE



- Open Bids – March 18, 2025
- Review/Certify Bids – March 19, 2025
- Bid Tab Posted to the PlanRoom – March 19, 2025
- Pre-Award Timeline – March 19 through March 21, 2025
- EPS Board Approval – March 24, 2025

All Subcontractor & Products Lists

must be submitted by: March 19, 2025

BID OPENING



Date: March 18, 2025

Time: 2:00 PM

**Location: Edwardsburg Public Schools Administration Building
69410 Section Street
Edwardsburg, MI 49112**

Q & A



Edwardsburg
INTERMEDIATE SCHOOL



Edwardsburg
PRIMARY SCHOOL

**Project Name: Edwardsburg Public
Schools - Intermediate and Primary
School Renovation**



DATE: March 4, 2025

TSC PROJECT NO.: 224050.03

PRE-BID MEETING SIGN-IN SHEET

COMPANY REPRESENTED	ATTENDEE NAME	EMAIL ADDRESS	PHONE NUMBER
EDWARDSBURG PUBLIC SCHOOLS	Dr. Courtney Szucs		
EDWARDSBURG PUBLIC SCHOOLS	Gail Enders		
EDWARDSBURG PUBLIC SCHOOLS	Christine Neff		
THE SKILLMAN CORPORATION	Max Tackett	mtackett@skillman.com	269-568-2433
THE SKILLMAN CORPORATION	Jay Bachtel	jmbachtel@skillman.com	269-830-8685
THE SKILLMAN CORPORATION	Caralee Sokolowski	csokolowski@skillman.com	269-568-1460
TOWERPINKSTER	Sue Potter	sue.potter@towerpinkster.com	

**Project Name: Edwardsburg Public
Schools - Intermediate and Primary
School Renovation**



DATE: March 4, 2025

TSC PROJECT NO.: 224050.03

PRE-BID MEETING SIGN-IN SHEET

COMPANY REPRESENTED	ATTENDEE NAME	EMAIL ADDRESS	PHONE NUMBER
Linear Electric	Kevin Stewart	Kevin@linearelectricalinc.net	269.927.6160
EMC	Dan Gearhart	Dgearhart@EMCelectricalLLC.com	571-323-5102
Brown + Brown	Luke Romine	luke@bbgc.us	574-340-1127
H+G Services	SCOTT MACKLING	SMACKLING@HGSERVICES.COM	574-214-6545
DYNAMIC Mechanical	Jay Hertel	JHertel@DYNAMICmechanical.net	574-976-6169
Tony Closson	Tony Closson	Tony.Closson@VFPfire.us	574-315-7856
Kevin Stewart H+G Services	Kevin Cleary	KCleary@HGSERVICES.COM	574-816-0938

Project Name: Edwardsburg Public
 Schools - Intermediate and Primary
 School Renovation



DATE: March 4, 2025

TSC PROJECT NO.: 224050.03

PRE-BID MEETING SIGN-IN SHEET

COMPANY REPRESENTED	ATTENDEE NAME	EMAIL ADDRESS	PHONE NUMBER
Gibson-Lewis	Matt Potter	mpotter@gl.nceusa.com	(574)-259-8581
Tower Pinkster	Dennis Knoff	dknoff@towerpinkster.com	
Thad Rieder	← Pearson Construction	trieder@pearsonconstruction.com	
Mandie Bazan	← Migala	mbazan@migalac1.com	
Lindsey Kraick			
Pat Partheus			